

• Receive data and conditions

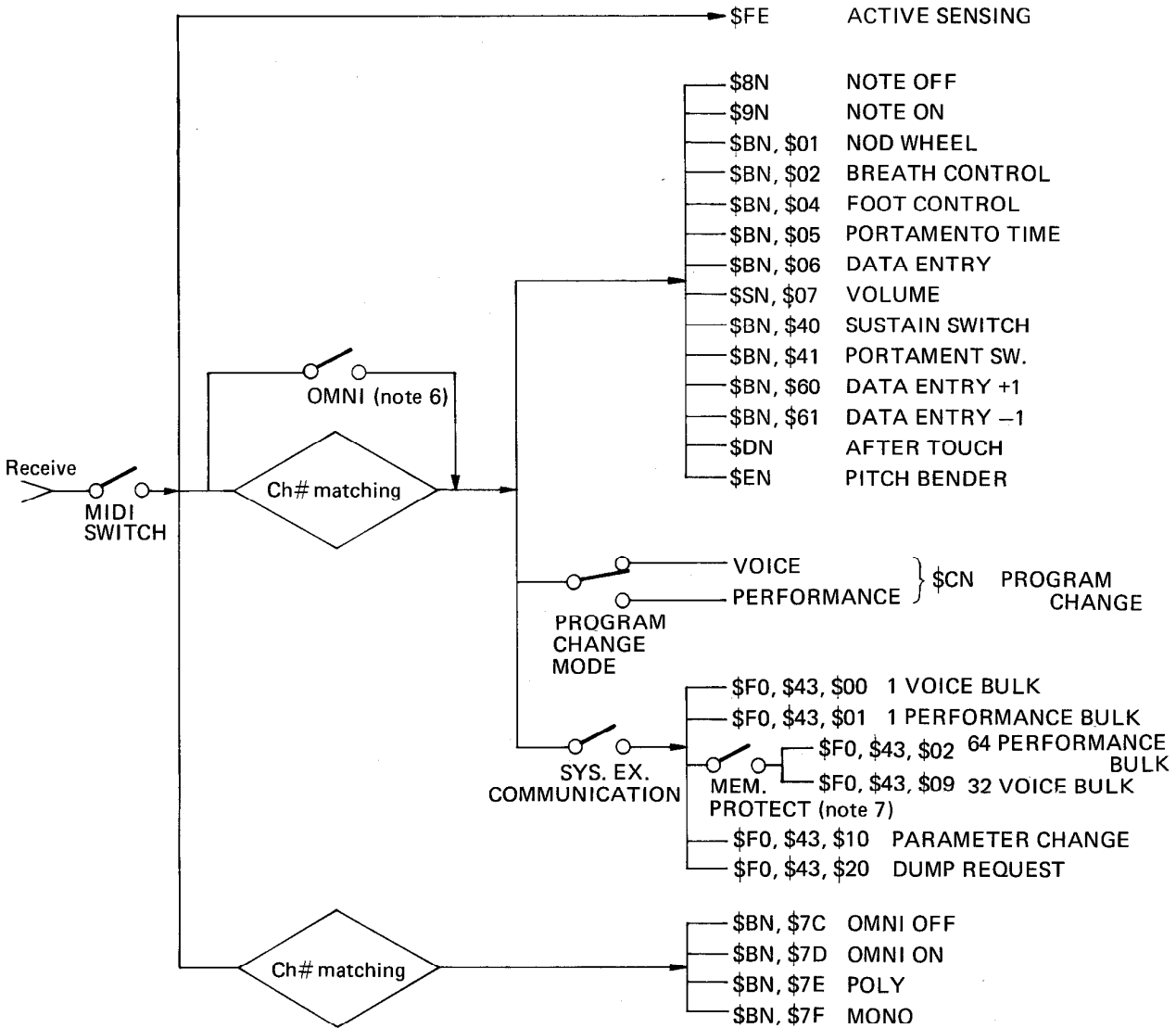

N: Ch# data

DX-1